

Aqua-Pure®

Spec # _____

Quantity _____

Models:

AP801 - Whole House Filter Housing

AP801-C - Whole House Filter System

AP800 Series Whole House Water Filters

Applications:

- Particulate & Rust
- Chlorine Taste & Odor¹

¹ The AP817 addresses Chlorine Taste and Odor

At a Glance:

- 1" NPT connections for high flow applications
- Ideal for larger homes



AP801 / AP801-C

Product Benefits:

- 1" inlet and outlet connections for easy installation and high flow rates
- Designed with built-in pressure relief for convenient cartridge change-out
- A variety of rigid AP800 Series particulate cartridges are available for high filtration efficiency and particulate capacity
- AP817 cartridges are available to address chlorine taste and odor reduction
- Aqua-Grip filter wrench included for fast and easy housing sump removal for changing cartridges
- Manufactured from FDA CFR-21 compliant materials
- Limited Warranty

Product Specifications:

Model No. (Part No.)	Inlet/ Outlet Size	Dimensions		Approx. Weight	Flow Rate ³	Temp. Range	Pressure Range	Std. Replacement Ctg. No.	Degree of Filtration
		Height	Diameter						
AP801 (55857-01)	1" NPT	13-5/16" (33.8 cm)	7-1/4" (18.4 cm)	7 lbs. (3.2 kg)	N/A	40-100°F (4.4-37.8°C)	25-100 psi (172-690 kPa)	AP810 (not included)	N/A
AP801-C ² (55857-16)	1" NPT	13-15/16" (35.4 cm)		7.51 lbs. (3.4 kg)				20 gpm (75.7 lpm)	AP810 (included)

¹ The AP817 cartridge addresses Chlorine Taste and Odor

² "C" denotes Complete Series, includes housing, bracket, wrench and AP810 cartridge

³ Flow rate is dependant on replacement cartridge used. Please see the chart on page 2 for details.

Aqua-Pure®

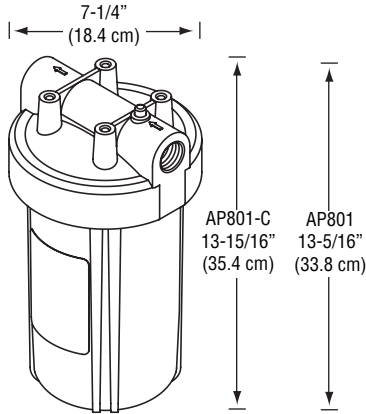

AP801 / AP801-C

Spec # _____

Quantity _____

Model Number _____

Part Number _____

Specifications:

- 1" NPT inlet and outlet ports
- Systems are a single vessel design
- Systems are manufactured from FDA CFR-21 compliant materials
- Systems have a maximum operating pressure of 100 psi (690 kPa) and operating temperature of 100°F (37.8°C)
- AP801-C comes with mounting bracket, wrench and AP810 cartridge
- Systems have a pressure relief button

Easy Installation:

CAUTION: Diagram shown is for reference purposes only. Read installation and operation manual prior to installing the unit.

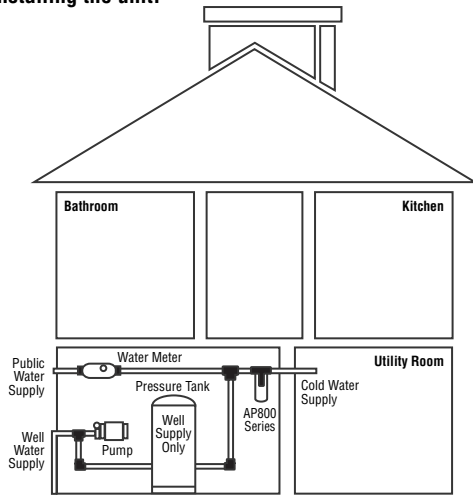

AP800 Series Replacement Cartridge Options

Cartridge Model	Particulate Load	Nominal Micron Rating	Application		Rated Flow Rate
			Particulate/Rust	Chlorine Taste & Odor	
AP810	Normal	5	•		20 gpm (75.7 lpm)
AP811	Medium	25	•		20 gpm (75.7 lpm)
AP814	Heavy	50	•		20 gpm (75.7 lpm)
AP817	Normal	25		•	10 gpm (37.9 lpm)

⚠ WARNING: To reduce the risk associated with the ingestion of contaminants:

- Do not use with water that is microbiologically unsafe or of unknown quality without adequate disinfection before or after the system.

3M Purification Inc. recommends regularly scheduled maintenance and replacement of the filter cartridge(s) in order for the product to perform as advertised/sold. 3M Purification Inc. shall not be liable for system failures due to improper maintenance.

CAUTION: To reduce the risk associated with property damage due to water leakage:

- The disposable filter cartridge **MUST** be replaced every six (6) months, at the rated capacity or sooner if a noticeable reduction in flow rate occurs.

Limited Warranty:

3M Purification Inc. warrants this Product only to be free from defects in material and workmanship for ten (10) years from the date of purchase. The disposable filter cartridge or membrane is warranted from defects in material and workmanship for a period of one (1) year from the date of purchase. This warranty does not cover failures resulting from abuse, misuse, alteration or damage not caused by 3M Purification Inc. or failure to follow installation and use instructions. No warranty is given as to the service life of any filter cartridge or membrane as it will vary with local water conditions and water consumption. **3M PURIFICATION INC. MAKES NO OTHER WARRANTIES OR CONDITIONS, EXPRESS OR IMPLIED, INCLUDING, BUT NOT LIMITED TO, ANY IMPLIED WARRANTY OR CONDITION OF MERCHANTABILITY OR FITNESS FOR A PARTICULAR PURPOSE OR ANY IMPLIED WARRANTY OR CONDITION ARISING OUT OF A COURSE OF DEALING, CUSTOMER OR USAGE OF TRADE.** If the Product fails to satisfy this Limited Warranty during the warranty period, 3M Purification Inc. at its option will replace the Product or refund your Product purchase price. This warranty does not cover labor. **The remedy stated in this paragraph is Customer's sole remedy and 3M Purification Inc.'s exclusive obligation. For additional information, see the entire Limited Warranty located in the product Installation and Operating Instruction Manual.**

Limitation of Liability. 3M Purification Inc. will not be liable for any loss or damage arising from this 3M Purification Inc. product, whether direct, indirect, special, incidental, or consequential, regardless of the legal theory asserted, including warranty, contract, negligence or strict liability. Some states and countries do not allow the exclusion or limitation of incidental or consequential damages, so the above limitation or exclusion may not apply to you.

Distributed by:

3M

3M Purification Inc.
400 Research Parkway
Meriden, CT 06450 U.S.A.
Toll Free: 800.222.7880
Worldwide: 203.237.5541
Fax: 203.238.8701
www.aquapure.com • www.3mpurification.com

3M is a trademark of 3M Company.
Aqua-Pure is a trademark of 3M Company used under license.
© 2013 3M Company. All rights reserved.
70020192889 REV 0613